



AUS-SPEC

Infrastructure Specifications

1101 Traffic Management



1101 TRAFFIC MANAGEMENT

IMPORTANT: This document has been adapted from the NATSPEC suite of specification templates for use in the MidCoast Council area by both Council and industry. NATSPEC regularly updates the base templates (currently in April and October each year), and Council may incorporate changes into its version of AUS-SPEC from time to time. To assist in highlighting any changes made by Council to the NATSPEC templates, the following conventions are used.

- See ANNEXURE M at the end of this document which contains (where practical) MidCoast Council customisations (also known as 'office master' text). References to the Annexure are to also be inserted at relevant clauses in the main body of the document.
- Where content is added to the main body of the document, it is to be shown **in brown text like this**.
- Where content is deleted or excluded from the main body of the document, it is to be shown ~~struck through like this~~. Such clauses are to have no effect.

Where there is a conflict between main body text and MidCoast Council specific clauses, Council's specific clauses shall prevail.

1 GENERAL**1.1 RESPONSIBILITIES****General**

Traffic management: Provide management for the safe movement of traffic and the protection of persons or property through and/or around the work site. Construct the Works with the least possible obstruction to traffic.

Authority requirements: This worksection does not override any applicable State or Local Government legislation and is to be read in conjunction with AS 1742.3 and the applicable State **and Local** Road Authority traffic management specification.

1.2 CROSS REFERENCES**General**

Requirement: This worksection is not a self-contained specification. In addition to the requirements of this worksection, conform to the following:

- 0136 *General requirements (Construction)*.
- 0152 *Schedule of rates (Construction)*.
- 0161 *Quality management (Construction)*.
- 1102 *Control of erosion and sedimentation (Construction)*.
- 1111 *Clearing and grubbing*.
- 1112 *Earthworks (Road reserve)*.
- 1121 *Open drains*.
- 1141 *Flexible pavement base and subbase*.
- 1143 *Sprayed bituminous surfacing*.
- 1144 *Asphalt (Roadways)*.
- 1195 *Rigid road safety barrier systems*.
- 1194 *Non-rigid road safety barrier systems*.
- 1351 *Stormwater drainage (Construction)*.
- 1352 *Pipe drainage*.
- 1354 *Drainage structures*.

1.3 STANDARDS**General**

Traffic control: To AS 1742.3 for works on or adjacent to roads.

Traffic management: To Austroads AGTM series.

Temporary traffic management: To Austroads AGTTM series.

Road management: To Austroads AGTM05.

1.4 INTERPRETATION

Definitions

General: For the purposes of this worksection the following definitions apply:

- Competent person: A person who has, through a combination of training, qualification and experience, acquired knowledge and skills enabling that person to correctly perform a specified task.
- Mobile work: Work that entails vehicles moving progressively along the roadway at speeds significantly lower than other traffic, with all traffic control devices being either vehicle mounted or regularly moved along the road.
- Online Planned Incident System (OPLINC): <https://myrta.com/oplinc2/pages/security/oplincLogin.jsf>
A system that has been designed to allow online lodgement of applications for any activity involving the closure of a traffic lane, or any activity likely to impact on the operational efficiency of, the State classified road network. Applications will be analysed and responded to by the Roads and Maritime Services (Transport Management Centre).
- Road safety barrier system: A physical barrier separating the work area and the travelled path, designed to resist penetration by an out of control vehicle and as far as reasonably practicable, to redirect out of control vehicles back into the travelled path.
- Traffic control plan (TCP)/Traffic guidance scheme (TGS): An arrangement of temporary traffic control devices to warn traffic and guide it around, through or past a worksite or temporary hazard.
- Traffic controller: A competent person whose duty is to control traffic at a work site.
- Traffic management plan (TMP): A document describing all essential traffic management matters associated with roadworks or works on roads. This includes risk assessment, traffic demand and accommodation traffic routing and control and provision for vulnerable road users and special vehicles such as buses, trams or over-dimensional vehicles.
- Transport for NSW (TfNSW), formerly Roads and Maritime Services (RMS): the state government agency with various transport management and administration functions within NSW. Also a concurrence authority for all works on traffic signals, and works within State and classified Regional roads, under Section 138(2) of the *Roads Act 1993*.
- Vehicle movement plan (VMP): A drawing showing the preferred travel paths for vehicles associated with a work site entering, leaving or crossing the through traffic stream.

1.5 SUBMISSIONS

Authority approvals

Requirement: Submit details of all authority approvals before commencing the works for which the approval is granted. **This is a HOLD POINT.** Include the following:

- Plan(s): Submit evidence of approvals from Councils and other authorities for temporary traffic arrangements. **Traffic management arrangements with potential to affect a State classified road or traffic signals on any road shall require a Road Occupancy Licence to be obtained via OPLINC.**
- Designer(s): Submit proof that each of the plan designer(s) / reviewer(s) holds a current SafeWork NSW traffic control accreditation card for the 'Prepare Work Zone Traffic Management Plan' category or equivalent.

Temporary speed zoning: Submit evidence of approval of temporary speed zoning requirements from the **Council's authorised staff**, Local Traffic Committee and/or State road authority.

Execution details

Plan(s): Submit the plan(s) as required in **ANNEXURE – PROJECT PLAN REQUIREMENTS** conforming to the following:

- Plan requirements: Conform to **PRE-CONSTRUCTION PLANNING**, as appropriate.
- Access: Include proposal of alternative access to roads and properties for vehicles and pedestrians for work affecting side roads and existing accesses.
- Construction under traffic: If required, include traffic arrangements details and methods for traffic control.

Records

Traffic controllers: Submit names of proposed traffic control personnel with a signed declaration that they are appropriately trained in the traffic control duties to TfNSW TCAWS and Austroads AGTTM07. Each such person shall hold a current SafeWork NSW traffic control accreditation card for the types of duties they will undertake.

1.6 INSPECTIONS**Notice**

General: Give notice so that inspection may be made of the following:

- Temporary roadways and detours: Completed stormwater drainage, wearing surface and linemarkings, and street lighting.
- Traffic control signs and devices: Completed installation including signals, safety barriers and containment fences.
- Plant delineation: If plant encroaches on traffic travel paths, completed installation of warning devices.
- Access: Completed alternative access for vehicles and pedestrians.
- Opening temporary roadways and detours to traffic: Completed roadway/detour and associated control measures.
- Opening completed work: Reinstatement of the area affected by the Works.

2 PRE-CONSTRUCTION PLANNING**2.1 TRAFFIC MANAGEMENT****Traffic management plan (TMP)**

Plan components: Prepare a TMP with the following:

- Traffic staging plan: If required, include details of the traffic staging arrangement and the time periods when each stage is in operation.
- Identify level of management provisions.
- Risk assessment: Identify and address risks associated with road safety, traffic management and road network issues specific to the site.
- Traffic control plan(s).
- Vehicle movement plan(s) showing travel paths for vehicles including for delivery, personnel and contractor's vehicles.
- Provisions for access to adjoining properties affected by the Works.
- Safe passage measures for workers/personnel, pedestrians and cyclists.
- Temporary speed zoning changes.
- Design drawings for temporary roadways and detours, including alignment and surface levels, pavement width and cross section, wearing surface and drainage details.
- Names and contact details of personnel responsible for the maintenance of traffic control devices and temporary roadways outside normal working hours. Include evidence that these details have been provided to the local police.

Plan preparation: Use a competent person to prepare the TMP.

Site copy: Keep a copy of the approved TMP on-site at all times. Use the plan for maintaining traffic control devices and to check traffic arrangement.

Level of management provisions

Requirement: Conform to one of the following levels of provisions to TfNSW TCAWS and Austroads AGTTM02:

- Short term and mobile works not involving full or part road closure.
- Works involving relatively simple part-roadway closures.
- Works involving complex traffic arrangements or staged works or both.

Traffic control plan (TCP)/Traffic guidance scheme (TGS)

Requirement: Prepare a TCP / TGS showing the following, as appropriate:

- Types and locations of permanent regulatory and advisory signs.

- Types and locations of temporary signs, including advance warning signs and speed zone signs.
- Pavement marking details, including types of delineation required, turning arrows, stop/holding lines and other road markings, types and positions of raised pavement markers and other delineation devices.
- Locations of permanent and temporary traffic signals.
- Locations and lengths of tapers and buffer zones.
- Locations of traffic controllers.
- Locations of entry and exit gates to the working areas, individually numbered and signposted.
- Pedestrians and cyclists paths.
- Details of side roads and access for adjoining properties and parking.
- Locations of safety barriers, barrier systems and end terminals.
- Locations of temporary lighting.

Road authority **accreditation**: Provide proof that persons preparing and approving a TCP / TGS hold a current SafeWork NSW accreditation card in the 'Prepare Work Zone Traffic Management Plan' category or equivalent.

Signage

Signage application/function: In the TCP/TGS, provide signs for the following:

- Protection of workers.
- To adequately warn of changes in surface condition and the presence of personnel or plant engaged in work on the road.
- For safely guiding road users through, around or past the work site.

Safety barriers

Location: To AS 1742.3 clauses 4.2.7 and 4.10.2, and at temporary embankments where the vertical height between the edge of the shoulder and the intersection of the embankment slope and natural surface exceeds 2 m.

Temporary embankment barriers: Corrugated steel or precast concrete safety barriers.

Road safety audit

Safety audits: If required, arrange for a commencement meeting, with the road safety auditor present, before implementing any traffic control measure to determine inspection points for auditing.

Audit report: After auditing of the TMP/TCP/TGS and receipt of the audit report, obtain directions for amending the plan documents. If amendment is required, obtain approval of revised documents before implementing control measures.

2.2 TEMPORARY ROADWAY DESIGN

Design standards

Requirement: If temporary roadways and detours or adjustments to existing lane configurations are required, design roadways conforming to the following:

- Design parameters: To **ANNEXURE – TEMPORARY ROADWAYS** and the recommendations of Austroads AGRD03 for alignment and grading.
- Intersections, interchanges and crossings: To the recommendations of Austroads AGTM06.
- Any DA consent conditions that apply.

Stormwater drainage

Design frequency: Provide drainage system to prevent run-off water overflowing on the road surface in any storm of intensity less than 1 in 5 year occurrence. Make sure the drainage system does not cause water ponding at any point.

Pavement drainage: Provide pavements with wearing surface and/or shoulders which will not pond water. Make sure temporary formations do not dam water.

Wearing surface

Wearing surface properties: Firm, even and skid resistant under all weather conditions and remain structurally sound during use.

Jointing to existing work: Extend wearing surface to the connecting roadway so that the finish is flush with existing roadway.

Design drawings

Requirement: Prepare drawings showing the following:

- Alignment and grading at a horizontal scale of 1:2000 for rural roads and 1:500 for urban roads, extending 100 m beyond the limits of the temporary roadway/detour.
- A sight distance diagram if opposing traffic is to use a single carriageway.
- Intersections, and other locations where traffic may be required to make turning, merging or diverging movements, at a scale of 1:500.
- Pavement type, including wearing surface, base and subbase details.
- Details of pavement markings, signposting, safety barrier and traffic control devices at a scale of 1:500.
- Sufficient cross-sections to indicate the feasibility of making connections between various parts of the Works.
- Sufficient dimensions, especially lane widths, showing clearly the geometry and clearances of the Works.
- Roadside furniture.
- Stormwater drainage, including culverts and pits.
- Street lighting details, as appropriate.

3 MATERIALS

3.1 SIGNS

Standards

Sign selection: To AS 1742.3.

Manufacturing of signs: To AS 1743.

Details of each letter: To the figures in AS 1744.

Retroreflective materials: Class 1 material conforming to AS/NZS 1906.1.

Sign size: To AS 1742.3 Tables 4.1 and 4.14, the figures in AS 1743 and **ANNEXURE – SUPPLEMENTARY TEMPORARY WARNING SIGNS**.

Signs for night work: If work area is outside of the car headlight beams, provide floodlighting to AS 1742.3 clause 4.2.4.

Flashing arrow signs: To AS 4192 and installed to AS 1742.3 clause 4.14.

Dynamic message and road weather information: To SA TS 5719.

Other work site approach/departure signs

Signs supplementary (ST/SW) to those in AS 1742.3 and AS 1743: To **ANNEXURE – SUPPLEMENTARY TEMPORARY WARNING SIGNS**.

Application: Provide warning signs as follows:

- Heavy machinery crossing: SW5-22.
- Cycle hazard grooved road: T1-10 to AS 1743 if the road is grooved and is a hazard to cyclists.
- Tar spraying possible short delay: T3-11 to AS 1743 for bituminous surfacing works.
- Changed traffic conditions ahead: T1-1, T1-6, T1-23, T2-6 and T2-23 to 25 to AS 1743 on long term works, side tracks and detours.

3.2 BARRIERS AND FENCING

Barrier boards

Size, placement, material/colour: To AS 1742.3 clause 4.10.

Trestle supports:

- Material: Timber, metal or other suitable material.
- Colour: Yellow.
- Stability: Keep trestle in place with concrete blocks or sandbags.
- Bases: Keep the bases of trestles within the ends of the barrier boards.

Warning lamps: Provide barrier boards or trestles which allow for the mounting of traffic warning lamps.

High visibility flexible mesh fencing

Plastic mesh fencing: To AS 1742.3 clause 4.12.

Application: fencing for pedestrian containment or containment of workers.

Support: Fastened to steel star pickets/posts with cable ties or drawstring.

Location: As documented in the [TMP/TCP/TGS](#).

Safety barriers

Road safety barrier systems: To AS/NZS 3845.1.

Temporary delineators

Material and erection: To AS 1742.3 clause 4.11.1.

Location: Erect parallel to and in close proximity to traffic, as documented.

Boom barriers

Type and location: As documented.

Cones and bollards

Requirement: To AS 1742.3 clause 4.11.1.

Spacing: To AS 1742.3 Table 4.7.

Conditions of use: Unless cones are firmly fixed in position, use only while work is in progress or in locations where an employee is present to re-instate cones dislodged by traffic. Otherwise, use bollards or barriers.

Cones and bollards used under night conditions: Provide cones and bollards with retroreflective bands conforming to AS 1742.3.

3.3 LINEMARKING**General**

Existing linemarking: To AS 1742.3 clause 4.11.4 (a) and (b) for the period of work.

Temporary linemarking: To AS 1742.3 clause 4.11.4 (c), (d) and (e).

Superseded raised pavement markers: Remove immediately to AS 1742.3 clause 4.11.5.

Edge lining: Where the adjoining roadway is edge lined, edge line temporary roadway to match.

Temporary linemarking

Type: If temporary marking is required on the final wearing surface, use pavement marking tape.

Maintenance:

- Generally: If the pavement linemarking is deemed ineffective, re-mark within 48 hours.
- Raised pavement markers: If markers are deemed ineffective, replace within 24 hours.

Arrows

Single carriageway: If opened adjacent to or is used in lieu of an existing dual carriageway length, place pavement arrows showing the direction of traffic flow spaced at 500 m maximum.

Remove arrows: Remove arrows when the section is reincorporated as a dual carriageway.

3.4 TRAFFIC SIGNALS**Portable traffic signals**

Signal system: To AS 4191.

Application, installation and operation: To AS 1742.3 clause 4.14.

Temporary fixed traffic signals

Design and installation of signal system: To AS 1742.14.

Application: Longer term shuttle operations or for non-shuttle control of intersecting traffic flows.

Traffic warning lamps

Application: To AS 1742.3 clause 4.13.

Lamp maintenance: Clean lamps and make sure they are in good working order, and correctly aligned and positioned for the direction of traffic flow each night, before leaving the site.

4 EXECUTION

4.1 GENERAL

Traffic management

Requirement: Provide the following, as documented:

- Personnel, plant and traffic control devices.
- Temporary roadways and detours.
- Arrangement for traffic.

Safety: Provide traffic control measures with minimal safety risk and inconvenience to the workers and road users at all times, including pedestrians and cyclists.

Road safety audits

Construction phase auditing: If safety audits are required, obtain agreement for inspections and arrange for a road safety auditor to inspect the traffic control measures during daytime and night time conditions at the inspections points. If the measures are ineffective, revise the TMP and implement the appropriate measure.

Managing and implementing: To Austroads AGRS06 and Austroads AGRS06A.

Revisions to the TMP: Obtain agreement for amendments/decisions, and document and implement the amendments.

4.2 SIDE ROADS AND PROPERTY ACCESSES

Access

Requirement: Provide safe and convenient passage for vehicles, pedestrians and stock to and from side roads and property accesses connecting to the roadway.

Notice to property owners

Vehicular access: Where **alternative or temporary** access is required, due to particular construction activities, conform to the following:

- Obtain **concurrence from the Superintendent, the road authority (e.g. Council), and TfNSW if a classified road. This is a HOLD POINT.**
- Advise the property owners with a letter drop at least 24 hours before the interruption.
- Repeat this advice verbally to the property owner in a courteous manner.
- Keep interruptions to a minimum.

4.3 PERSONNEL

Traffic controllers

Application, equipment and position: To **TfNSW TCAWS** and Austroads AGTTM07.

Recognition marks: Controllers to wear a distinguishing mark on their outer garment indicating their authority.

Location of traffic controllers: Place to **TfNSW TCAWS** and Austroads AGTTM07:

- One traffic controller at the head of each traffic queue whilst it is halted.
- An additional traffic controller at the tail end of the queue where there is restricted sight distance and the possibility of approaching traffic colliding with the tail of the queue.

Where both ends of the work are not intervisible: Provide the traffic controller at each end with a two-way radio. Where this is not possible, station an intermediate traffic controller at a location where the extremities of the work is visible to provide cues to both controllers.

Night work control: In conjunction with a STOP/SLOW hand bat, use an illuminated red cone wand (torch) with a minimum capacity of 30,000 candela.

Night time lighting of traffic controller and work area: If floodlighting of the traffic controller and the work area adjacent is required, position floodlights above the work area, directed downwards and inclined slightly to illuminate the face of the STOP/SLOW bat.

- Floodlighting and glare: Make sure lights do not create glare for approaching drivers.
- Effects on neighbouring properties: Make sure high lighting levels do not adversely affect neighbouring residential property.

Approved clothing for work personnel

Clothing and use: To AS 1742.3 clause 4.21.

Potentially flammable clothing: Do not wear close to work likely to generate flame or hot splatter/molten metal.

4.4 PLANT AND CONTROL DEVICES**Plant delineation**

Plant and equipment: Where plant and equipment encroaches on traffic travel paths, direct traffic around encroachment as follows:

- In daylight conditions: Attach a fluorescent red flag to the outer end of the projection.
- In night or poor light conditions: Provide an additional traffic controller with an illuminated red wand.

Night time clearance: If traffic is permitted to use the whole or part of the existing road, remove all plant items and similar obstructions from the normal vehicle path to provide minimum 6 m lateral clearance where practicable, with minimum 1.2 m clearance of other dimensions.

Warning lamps: Light plant and equipment within 6 m of the normal vehicle path with minimum two yellow steady lamps suspended vertically from the point of obstruction nearest to a traffic lane, and one lamp at each end of the obstruction on the side furthest away from the traffic lane.

Traffic control signs and devices

Arrangement and placement of traffic control devices: To the approved Traffic control plan.

Signs no longer required: Cover and/or remove temporary control devices no longer required without delay to maintain unambiguous safe guidance to traffic.

Control device maintenance: Maintain control devices so that they are in good working order and in the correct positions day and night. Maintain signs so that they are neat, clean, clear and legible.

Non-conforming signs and devices: Repair or replace to TfNSW TCAWS and AGTTM06 section 4.5.

Sign installation: To TfNSW TCAWS, Austroads AGTTM06 section 2.1 and AGTTM03.

Temporary speed zoning

Requirement: If temporary speed limit has been approved by the Local Council Traffic Committee or State Road Authority, provide temporary speed zoning signs complete with posts and fittings.

Speed limit: To AS 1742.3 Table 4.2(E) and the applicable State Road Authority specification.

Temporary speed zoning signs: Erect signs, cover the signs when the speed zone is not in use, and remove the signs when the speed zone is no longer required.

Operation diary: Keep a diary recording operation times of the speed zone.

4.5 TEMPORARY ROADWAYS AND DETOURS**Stormwater drainage**

Requirement: Construct drainage system, as appropriate for the approved temporary roadway design, conforming to the following worksections:

- 1121 *Open drains*.
- 1351 *Stormwater drainage (Construction)*.
- 1352 *Pipe drainage*.
- 1354 *Drainage structures*.

Temporary roadways

Requirement: Construct temporary roadways conforming to the following worksections:

- 1102 *Control of erosion and sedimentation (Construction)*.
- 1111 *Clearing and grubbing*.
- 1112 *Earthworks (Road reserve)*.
- 1141 *Flexible pavement base and subbase*.

Temporary kerbing: If required for long term works as temporary medians, traffic islands or pavement edges, provide kerbing conforming to the following:

- Height: Maximum 150 mm.
- Securely fastened to the pavement.
- Clearly delineated.
- As seen by the approaching traffic is a 150 mm wide continuous line.

- Kerb and channel (gutter) in 1121 *Open drains*.

Wearing surface

Requirement: Construct surfacing, as appropriate for the approved temporary roadway design, conforming to one of the following:

- 1143 *Sprayed bituminous surfacing*.
- 1144 *Asphalt (Roadways)*.

Width of the wearing surface: As documented or the width of the traffic lanes plus the width of each shoulder.

Road safety barrier

Location: As documented on the **TMP/TCP/TGS**.

Corrugated steel or precast concrete safety barriers: If required, install conforming to the following worksections, as appropriate:

- 1194 *Non-rigid road safety barrier systems*.
- 1195 *Rigid road safety barrier systems*.

Water-filled plastic barriers: Use in locations where rigid barriers are not allowed, such as at corners or intersections:

- Buffer zone: Provide the manufacturer's recommended buffer zone on the approach side of water-filled barriers.
- Water level: Maintain the required level for all water ballasted safety barriers at all times.

Opening temporary roadways and detours to traffic

Requirement: Complete all signposting, pavement marking, safety barriers and portable or temporary traffic signals before opening the temporary roadways to traffic.

Traffic switch: Traffic switch to a temporary roadway or detour is only permitted if the usual workforce will be on site for two days minimum thereafter.

Retaining existing roadway: Arrange the opening of temporary roadways so that sections of the existing roadway being replaced are not disturbed for minimum 48 hours so that traffic can be redirected back onto the existing roadway in the event of temporary roadway failure.

Approval to open roadway: Do not open temporary roadways and detours (including portable or temporary traffic signals sites) to traffic without written approval. **This is a HOLD POINT.**

Maintenance during construction: Maintain road surface of temporary roadways and detours and any local roads used by the construction traffic so that it is safe for traffic, including:

- Maintaining existing pavement linemarkings, kerb and gutters, road shoulders and verges, drainage, signage and vegetation.
- Repairing potholes, surface drainage blockages or other failures without delay.
- Removing debris without delay.

Removal and restoration: Upon completion of the Works, remove the temporary roadways and/or detour arrangement and restore the area affected by the Works to a condition equivalent to that before commencement.

4.6 CONSTRUCTION UNDER TRAFFIC

Arrangement for traffic

Permission to construct under traffic: If a temporary roadway or a detour is not provided or available, construction under traffic may be permitted **subject to a Traffic Guidance Scheme being approved by Council (and TfNSW if for a State road)**, if the following is provided:

- Through traffic on a two lane roadway: Minimum 3.5 m lane width.
- Multilane roads: Minimum 3.5 m lane width in both directions.

Notification: Give minimum 5 working days' notice before carrying out work **under traffic flow in accordance with an approved Traffic Guidance Scheme. This is a WITNESS POINT.**

Carriageway restoration: Restore carriageway to a safe and trafficable state for through traffic before ceasing work each day.

4.7 OPENING TO TRAFFIC

Opening completed work

Notice: Provide at least 10 working days' written notice of the date of opening the Works to traffic. Obtain agreement for the procedure for opening including with the local Police.

Permanent signs and markings: Complete all permanent signposting, pavement markings, safety barriers and traffic signals required to complete the Works before opening to traffic.

Removal of temporary traffic control devices: Remove all temporary control devices no longer required for the safety of traffic, when part or all of the Works are opened to traffic.

Restoration: Restore the area to a condition equivalent to that at commencement.

5 ANNEXURES

5.1 ANNEXURE – PROJECT PLAN REQUIREMENTS

Plan type	Required?*	
Traffic management plan (TMP)	Yes <input type="checkbox"/>	No <input type="checkbox"/>
Traffic control plan (TCP)/Traffic guidance scheme (TGS)	Yes <input type="checkbox"/>	No <input type="checkbox"/>
Traffic staging plan	Yes <input type="checkbox"/>	No <input type="checkbox"/>
Road safety audit of TMP/TCP/TGS	Yes <input type="checkbox"/>	No <input type="checkbox"/>
Vehicle movement plan (VMP)	Yes <input type="checkbox"/>	No <input type="checkbox"/>
*Check the box applicable for the project. For private development works, documentation will be subject to the requirements of the road authority (e.g. Council) and TfNSW (for State roads) permits, and any DA consent conditions.		

5.2 ANNEXURE – TEMPORARY ROADWAYS

Temporary roadways design parameters schedule

Property	Minimum value/required?*	
Design travel speed (km/hr)		
Traffic lane width (m)		
Shoulder width (m)		
Shoulder seal	Yes* <input type="checkbox"/>	No* <input type="checkbox"/>
*Check the box applicable for the project. For private development works, parameters will be subject to the requirements of the road authority (e.g. Council) and TfNSW (for State roads) permits, and any DA consent conditions.		

Temporary roadways materials schedule

Pavement layer	Type/material	Minimum thickness (mm)
Wearing surface		
Base		
Subbase		

Typical minimum parameters (subject to design traffic):

Wearing surface:

- Type/material: Initial seal.
- Minimum thickness: 10 mm.

Base:

- Type/material: DGB20.
- Minimum thickness: 100 mm.

Subbase:

- Type/material: DGS20.
- Minimum thickness: 200 mm.

5.3 ANNEXURE – SUPPLEMENTARY TEMPORARY WARNING SIGNS

Sign SW5-22

Dimensions: mm.

Colours: Black letters and border on yellow retroreflective background.

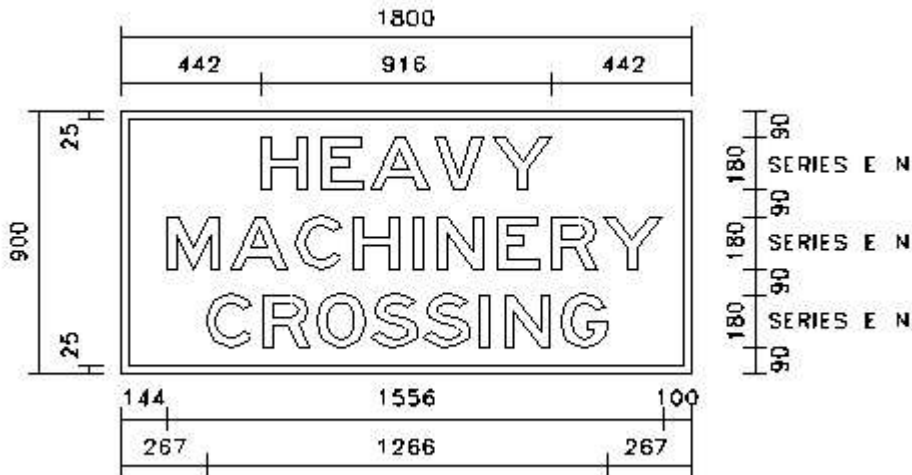

Sign ST1-10

Dimensions: mm.

Colours: Black letters and border on yellow retroreflective background.

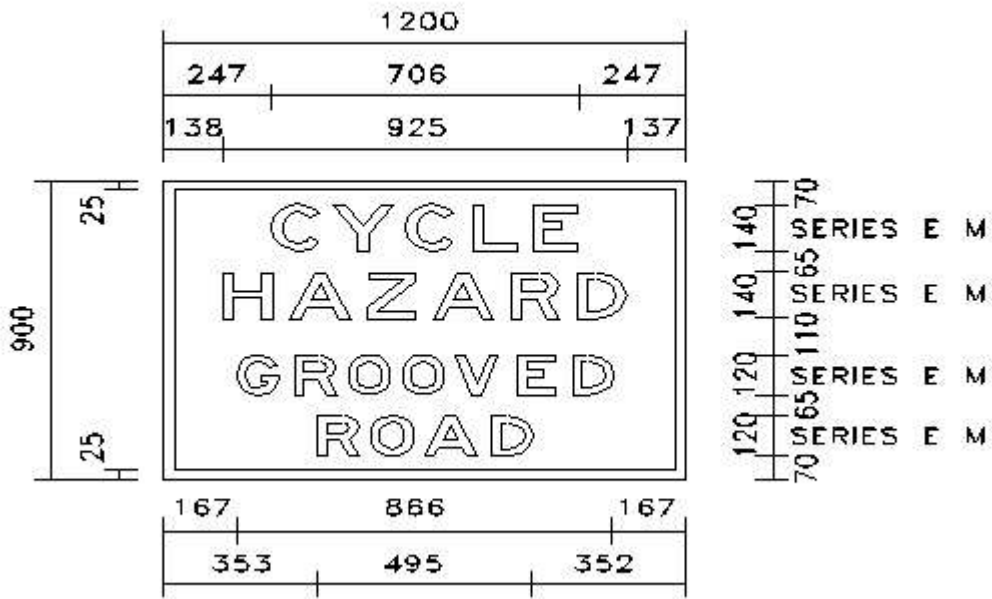

Sign ST3-1

Dimensions: mm.

Colours: Black letters and border on yellow retroreflective background.

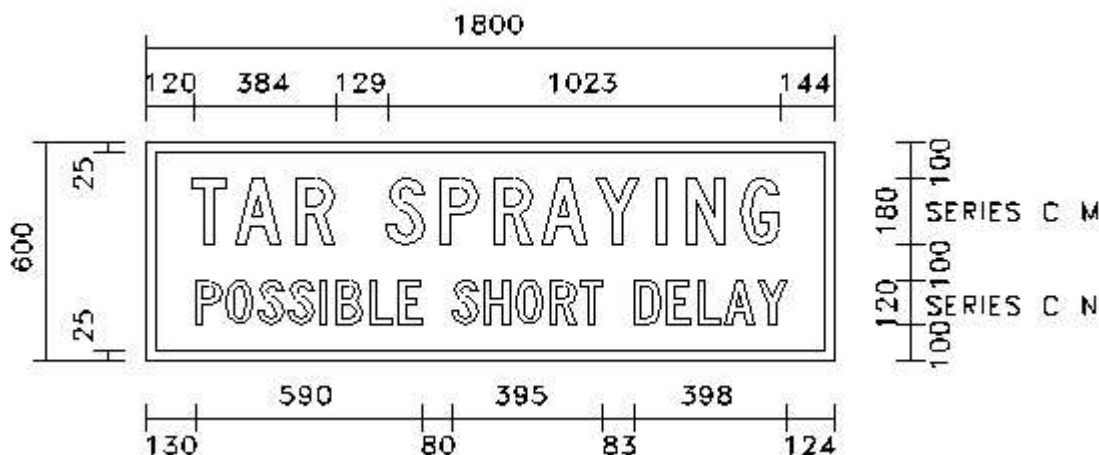

5.4 ANNEXURE – SUMMARY OF HOLD AND WITNESS POINTS

For private developments, certain Hold and Witness Points where specifically noted below require representatives of both the road authorities (e.g. Council, and TfNSW for State classified roads) to authorise release.

Clause and description	Type*	Submission/Inspection details	Submission/Notice times	Process held
SUBMISSIONS, Execution details Plan(s)	H – Road authorities (Council, TfNSW via OPLINC if required) and Superintendent	Plans and documents of the TMP.	2 weeks if pavement/ drainage works is not required. First obtain Roads Act Section 138 permit from Council, and TfNSW (if a State or Regional classified road) if pavement/ drainage works is required.	Commencement.
SUBMISSIONS, Authority approvals Plan(s)	H – Road authorities (Council, TfNSW if required) and Superintendent	Evidence of approvals for temporary traffic arrangements, including any alternative or temporary access arrangements to properties.	4 weeks before commencement.	Commencement.
SUBMISSIONS, Authority approvals Temporary speed zoning	H – Road authorities (Council, TfNSW via OPLINC if required) and Superintendent	Evidence of approvals for changes to speed zoning.	5 weeks before implementation.	Implementation of speed zoning.
INSPECTIONS, Notice Temporary roadways and detours or arrangement to work under traffic	W – Road authorities (Council, TfNSW if required) and Superintendent	Completed roadway/detour construction or commencement of work under traffic.	5 days before installing control signs and devices.	-

Clause and description	Type*	Submission/Inspection details	Submission/Notice times	Process held
INSPECTIONS, Notice Traffic control signs and devices	W – Road authorities (Council, TfNSW if required) and Superintendent	Completed installation of signs and devices.	1 day before opening to traffic.	-
INSPECTIONS, Notice Access	W – Road authorities (Council, TfNSW if required) and Superintendent	Completed alternative access.	1 day before opening to traffic.	-
INSPECTIONS, Notice Plant delineation	W – Road authorities (Council, TfNSW if required) and Superintendent	Completed warning devices installation.	1 day before opening to traffic.	-
INSPECTIONS, Notice Temporary roadways and detours	H – Road authorities (Council, TfNSW if required) and Superintendent	Completed roadway/detour.	3 days before opening to traffic.	Opening to traffic.
INSPECTIONS, Notice Opening completed work	H – Road authorities (Council, TfNSW if required) and Superintendent	Reinstated area affected by the Works.	10 days before switching traffic (clause 4.7).	Opening of completed work to traffic.
*H = Hold Point, W = Witness Point				

5.5 ANNEXURE – PAY ITEMS

This schedule applies to Council projects. For private development works use of this schedule is optional, at the Superintendent's discretion.

Pay items	Unit of measurement	Schedule rate inclusions
1101.1 Traffic management	Lump sum	All costs associated with the documentation and approvals of: <ul style="list-style-type: none"> - The design of temporary roadways and detours, traffic switching operations, the provision of traffic controllers, signposting, roadmarkings, raised pavement markers, lights, barriers. - Other traffic control devices required for the safe movement of traffic and the protection of persons and property. Progress payments work done under this item is to be made on a pro-rata basis, as appropriate for the duration of the Contract.
Temporary roadways and detours – Drainage	Per m ² for clearing and grubbing Per m ² for subgrade preparation Per m ² for earthworks	To the following worksections: <ul style="list-style-type: none"> - 1121 Open drains.

Pay items	Unit of measurement	Schedule rate inclusions
	Per m ² solid for subbase and base pavement For temporary roadworks refer to the worksections	- 1351 Stormwater drainage (Construction). - 1352 Pipe drainage. - 1354 Drainage structures.
Temporary roadways and detours – Temporary roadways	Per m ² for bitumen seal	To the following worksections: - 1102 Control of erosion and sedimentation (Construction). - 1111 Clearing and grubbing. - 1112 Earthworks (Road reserve). - 1141 Flexible pavement base and subbase.
Temporary roadways and detours – Wearing surface	Refer to the worksections	To one of the following worksections: - 1143 Sprayed bituminous surfacing. - 1144 Asphalt (Roadways).
Temporary roadways and detours – Road safety barriers		To the following worksections: - 1194 Non-rigid road safety barrier systems. - 1195 Rigid road safety barrier systems.

5.6 ANNEXURE - REFERENCED DOCUMENTS

The following documents are incorporated into this worksection by reference:

AS 1742		Manual of uniform traffic control devices
AS 1742.3	2019	Traffic control for works on roads
AS 1742.14	2014	Traffic signals
AS 1743	2018	Road signs - Specifications
AS 1744	2015	Standard alphabets for road signs
AS 1906		Retroreflective materials and devices for road traffic control purposes
AS/NZS 1906.1	2017	Retroreflective sheeting
AS/NZS 3845		Road safety barrier systems and devices
AS/NZS 3845.1	2015	Road safety barrier systems
AS 4191	2015	Portable traffic signal systems
AS 4192	2006	Illuminated flashing arrow signs
Austrroads AGRD		Guide to road design
Austrroads AGRD03	2016	Geometric design
Austrroads AGRS		Guide to road safety
Austrroads AGRS06	2019	Managing road safety audits
Austrroads AGRS06A	2019	Implementing road safety audits
Austrroads AGTM		Guide to traffic management
Austrroads AGTM05	2020	Link management
Austrroads AGTM06	2020	Intersections, interchanges and crossings management
Austrroads AGTTM		Guide to temporary traffic management
Austrroads AGTTM02	2019	Traffic management planning
Austrroads AGTTM03	2019	Static worksites
Austrroads AGTTM06	2019	Field staff
Austrroads AGTTM07	2019	Traffic controllers
SA TS 5719	2017	Communications protocol for dynamic message signs and road weather information systems
TCAWS	2020	TfNSW Traffic Control at Work Sites Manual

6 ANNEXURE M – MIDCOAST COUNCIL SPECIFIC CLAUSES

M1.	Variations to or non-conformances with Council's AUS-SPEC are to be evaluated with reference to the procedure in Council's <i>Development Engineering Handbook</i> . Acceptance is to be obtained in writing from: <ul style="list-style-type: none"> a) an authorised representative of Council's Director of Infrastructure and Engineering Services, or b) an accredited certifier where they are the Principal Certifier and hold the relevant accreditation category for the type of work. 	Variation procedure
M2.	This specification applies in addition to any development consent (DA) conditions. If there is any inconsistency, the conditions of consent shall prevail.	DA conditions
M3.	Refer to the MidCoast Council <i>Development Engineering Handbook</i> for final inspection, works-as-executed and handover requirements.	Completion

7 AMENDMENT HISTORY

0	14/12/2020	First Published
---	------------	-----------------